

# LOCATOR

**INSIZE PLUS**  
MADE IN USA

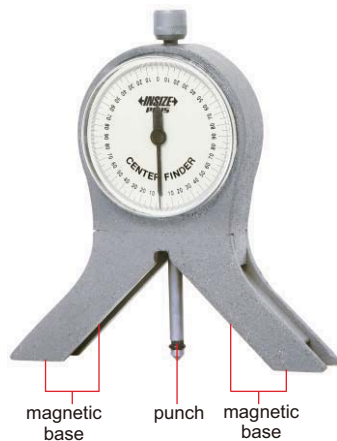
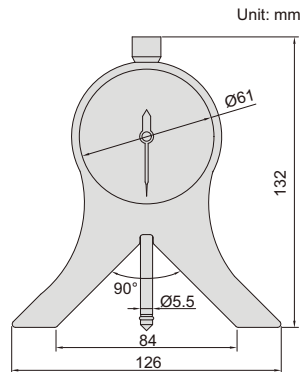

**2849-90**

- Mark the position when drilling, milling or welding, suitable for cylindrical and rectangular workpieces
- The punch hardness is HRC59-63
- Optional accessory: punch (code **2849-P1**)

Code	Range	Graduation	Accuracy	Dial reading
<b>2849-90</b>	4×90°	1°	±1°	0-90-0-90-0



mark the center position

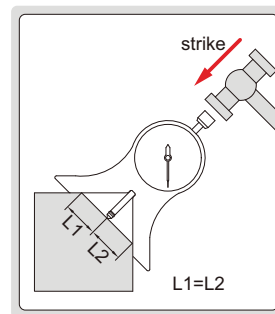

mark the angle on cylindrical workpieces

